

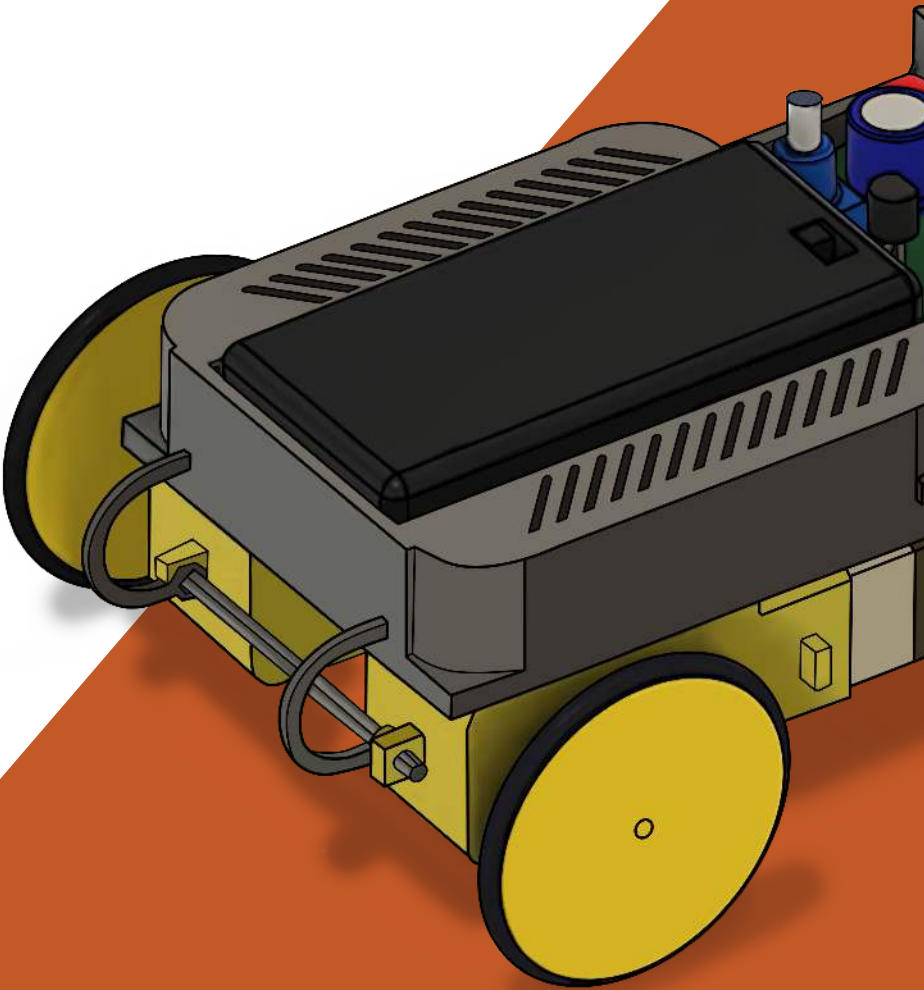

AUTODESK Fusion 360

Tips and Techniques





AUTODESK Fusion 360

Autodesk Fusion 360 is an industry recognized (web based tool or desktop app) CAD and CAM platform. Educators and students can access Fusion 360 for FREE on any device, anywhere, anytime. Educators and students can use Fusion 360 to take their problem solving, critical thinking, and creativity skills to the next level - from initial design through to manufacturing, Fusion 360 can bring independent exploration or project-based learning to life.

With one unified CAD model, students can work together to share information and ideas in real time with commenting, increasing efficiency and collaboration in the classroom. Educators can leave feedback on student assignments just the same with mark-up capability. Educators and students can work in both 2D and 3D supporting essential design methods with sub-divisional, history based, direct, and mesh modeling tools. There are also a variety of modeling methods to fit all learning preferences.

We have lesson plans and support for teachers to feel confident teaching design and manufacturing with Fusion 360. Be the facilitator and watch your students become the experts. Help your students develop a sense of curiosity and a passion for CAD and CAM-related fields with Fusion 360 and inspire your students on their path to future careers as designers and makers.



Tinkercad to Fusion 360

Level up your Tinkercad designs with Fusion 360



Design

Have your students model and analyze form, fit, and function with diverse modeling methods



Simulate

Students can predict how their model will perform digitally, prior to any physical prototyping



Document

The drawing workspace lets your students document their design intent and dimensions



Render

Students can create photo-realistic and in-context images to show off their work



Animate

Have your students create videos that demonstrate how their designs fit together



Manufacture

Students can make their designs real using 3D printing, laser cutting, CNC machining and more



Automated Modeling

Have your students automate the process of creating and exploring new design concepts



Generative Design

Students can generate multiple solutions based on real-world manufacturing constraints



Bring Fusion 360 into the classroom

Set up your digital classroom and folder structure



Tinkercad to Fusion 360

Fusion 360 is a cloud-based 3D modeling, simulation, and manufacturing software platform for professional design, engineering and manufacturing. Fusion 360 is not just for CAD, or simulation, or manufacturing, or documentation, or rendering - it is an all-in-one software platform for all of these capabilities.

Fusion 360 allows students to design, simulate, and test their designs in a native virtual environment before building them in the real world using the manufacturing tools and features in Fusion 360, like 3D printing and CAM.

Fusion 360 is the perfect next step for Tinkercad users that start finding limitations to making their ideas real. When you're ready to design and make like the pros, Fusion 360 will let you:

- Gain detailed control of all shapes
- Enhance the quality of your 3D prints
- Assemble and animate your models
- Bring designs to life with realistic images

Educators and students can get Fusion 360 for free by creating an Autodesk account and verifying eligibility.



Take your design to the next level

Get started and download Fusion 360 today.

Step 1:

Select 'Educator' (or your respective role) from the drop down list provided. Click next.

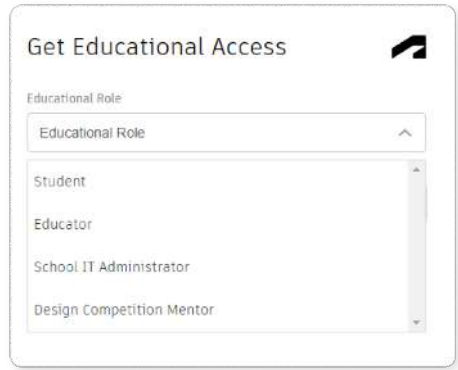

Get Educational Access

Educational Role

Educational Role

Student

Educator

School IT Administrator

Design Competition Mentor

Step 2:

Create your account by filling out the information in the spaces provided. Please be sure to use your education institution email address and not your personal email address.

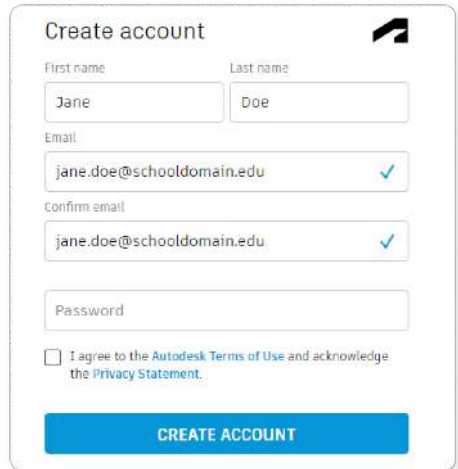

Create account

First name Last name

Jane Doe

Email

jane.doe@schooldomain.edu

confirm email

jane.doe@schooldomain.edu

Password

I agree to the [Autodesk Terms of Use](#) and acknowledge the [Privacy Statement](#).

CREATE ACCOUNT

Step 3:

Head to your email inbox and follow the instructions to verify your educational eligibility. You may be asked to submit proof of your educator status.

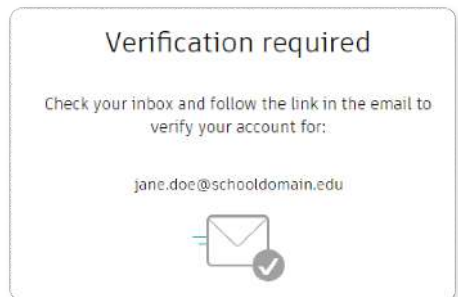

Verification required

Check your inbox and follow the link in the email to verify your account for:

jane.doe@schooldomain.edu



Step 4:

To get your students set up with access, head back to autodesk.com/education/edu-software and click on the class/lab tab. You'll be presented with an option to set up single user subscriptions. Click accept, then activate class. You'll be taken to a page where you can assign those licenses to the students in your class.



Design

The design workspace is where your students will spend most of their time as they create, modify, and refine their 3D designs. It is the heart of Fusion 360. This is where the creativity and problem-solving skills of your students will truly shine.

In the design workspace, your students can sketch out their designs, add dimensions and constraints, and then turn those sketches into 3D models that can be manipulated and refined with a high degree of control and level of detail.

They can experiment with different approaches, shapes, and more fluid forms, then use Fusion 360's simulation tools to test their designs, coming back to the design workspace to refine until they are just right. The design workspace in Fusion 360 is where the magic happens.



Multiple tool sets:

There are a range of tool sets in the design workspace, including solid modeling tools, surface modeling, freeform tools and sheet metal tools. You can explore these further by clicking on the words above these icons.



Modifying shapes:

The modify tools enable the editing of shapes and geometry to achieve additional levels of design refinement.

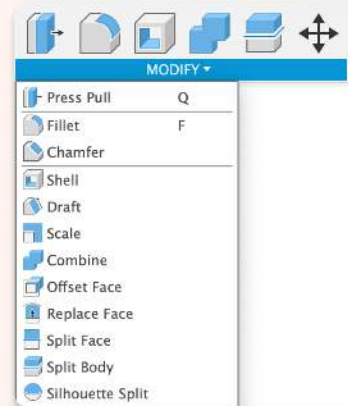



Simulate

The simulation workspace in Fusion 360 provides students with a comprehensive set of tools for analyzing the real-world performance of their designs before they are physically built. When you first open the simulation workspace in Fusion 360, you will see a number of different options for types of simulation that are available - including stress analysis, modal analysis, and thermal analysis. These tools allow you to test the performance of your design under different conditions, such as different temperatures or loads.

This means that you can test your design in a virtual environment and make changes before building a physical prototype. This can save time and resources, as well as help students learn about the importance of testing and iteration in the design process.

The screenshot displays a grid of simulation options in Fusion 360. The options are:

- Static Stress (highlighted with a blue border)
- Modal Frequencies
- Electronics Cooling
- Thermal
- Thermal Stress
- Structural Buckling
- Nonlinear Static Stress
- Quasi-static Event Simulation
- Dynamic Event Simulation
- Shape Optimization
- Injection Molding Simulation

Below the grid is a link: [Help me choose a study type.](#)

On the right, a preview window shows a 3D model of a mechanical part with a color-coded stress distribution. Below the preview, the text reads:

Static Stress

Analyze the deformation and stress into the model from structural loads and constraints.

From the results, you can investigate displacement, stresses, and common failure criteria. The results are calculated based on assumption of linear response to the stress.

At the bottom right of the preview window are two buttons: **Create Study** and **Cancel**.



Using the cloud:

Once designs have been sent for simulation, students can carry on working or return later to see and analyze their results.



Document

The drawings workspace is where your students can create detailed 2D drawings of their designs, complete with dimensions, annotations, and other important information to document their design work.

These drawings serve as a critical means of communication between designers, engineers, and manufacturers. Drawings ensure that everyone is on the same page when it comes to the design and production process.

With Fusion 360's drawings workspace, your students can easily create professional-grade technical drawings that accurately represent their designs, directly from their designs. They can also create exploded views, section views, and other specialized drawings that help to convey complex ideas and design intent in a clear and concise manner.

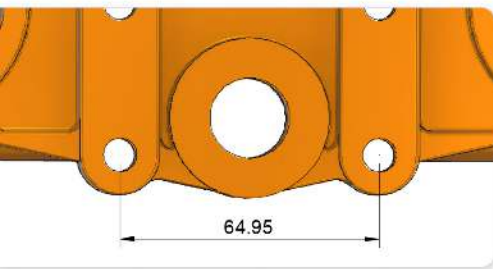

Dimensions:

Students can create 2D drawings of their 3D parts to document them and display critical dimensions for communication.

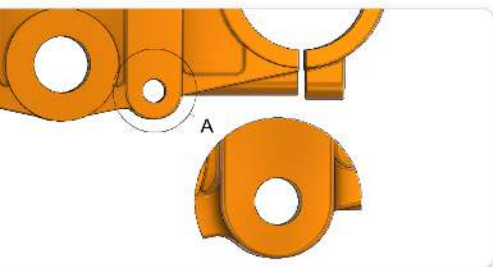

Design intent:

Tools in the drawings workspace let students highlight specific areas of detail relevant to their designs.



Render

Rendering is the process of creating realistic 3D images of your designs, making them appear as if they were photographed in real life. This is an incredibly powerful tool for students to visualize and present their designs, whether it is for a class project or a competition.

Students can bring their designs to life in a whole new way. They can experiment with different materials and finishes, see how light interacts with their designs, and create stunning visualizations that will wow their classmates and teachers alike.

Rendering in Fusion 360 is super simple with ready made materials and appearances that can be dragged and dropped directly onto the different parts or faces of a design. You can also add decals to surfaces and use photorealistic backgrounds to show parts and assemblies in context.



Realistic materials:

All material appearances in the rendering workspace are editable, so you can completely customize designs by scaling textures like wood grain or making them less reflective.



Animate

Animation is the process of bringing a design to life through movement and storytelling. In Fusion 360's animation workspace, your students can create dynamic animations that showcase their designs in action. Whether it is a mechanical assembly, a product demonstration, or an exploded view, animation allows your students to communicate their designs in a clear and engaging way.

Your students can create key frames and control the movement of their designs. However, it is not just about the end result - the process of creating an animation in Fusion 360 is a valuable learning experience for your students. It encourages them to think critically about how their designs will function in the real world, and challenges them to problem-solve and refine their designs for optimal performance.



Exploded views:

Tools in the animation workspace let students automatically explode their designs to show all the parts and components in the design.



Manufacture

The manufacturing tools in Fusion 360 allow students to generate toolpaths for CNC machines, 3D printers, and other manufacturing processes. This is where to start when you want to introduce your students to the world of digital fabrication and product manufacturing.

With its comprehensive set of manufacturing tools and easy-to-use interface, it allows students to explore the world of CAD and digital manufacturing in a fun and engaging way.

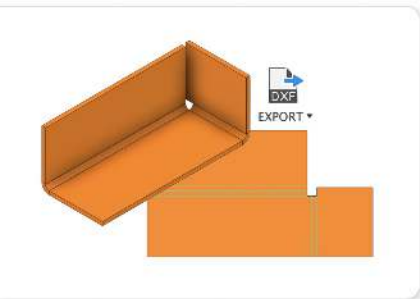

Profile Cutting:

2D profiles for laser cutting can be exported as .dxf or svg files from sketches or prepared ready for your machine.

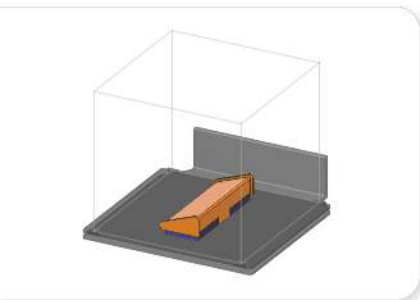

3D Printing:

Designs can be exported for 3D printing or prepared in Fusion 360 using the native 3D printing slicing tools that maintain the link to the original 3D designs.

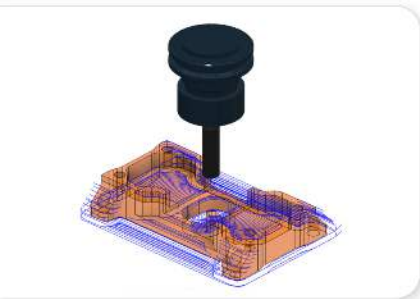

CAM for CNC Machining

Extensive 2.5 axis to 5 axis toolpaths enable the realization of student designs using most CNC machines.

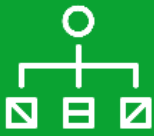

Automated Modeling

Another exciting new tool that can be found in Fusion 360 is automated modeling. This technology automates the process of creating and exploring new design concepts based on simple definitions of what to connect and what to avoid.

Using just those basic inputs, Fusion 360 can create a host of potential options in a matter of seconds. In the classroom, this can be used to inspire students to think differently about their designs or give them a starting point from which they can unleash their creativity and explore those ‘what if’ scenarios.

Taking it one step further, students can use Automated Modeling to compare their own designs to an optimized solution generated by Fusion 360 to see alternative ways to solve the problem.

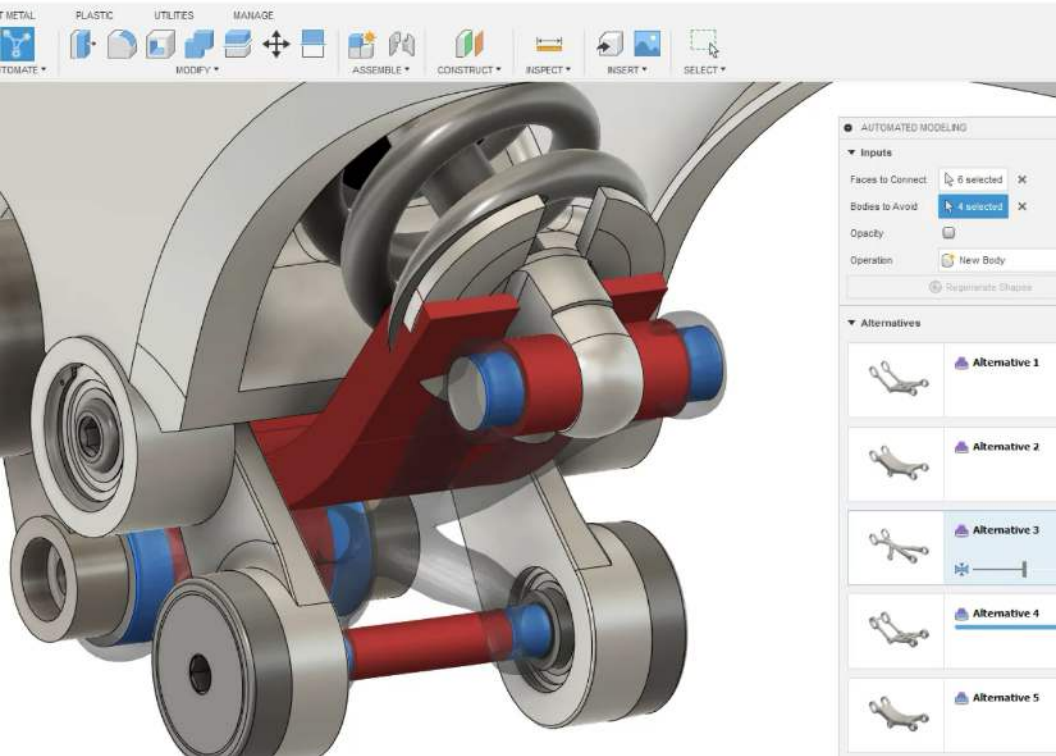

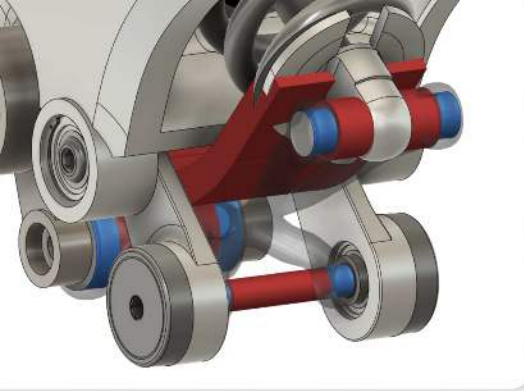

Setting up:

The user selects the face that they want to connect as well as the bodies that they need to avoid.

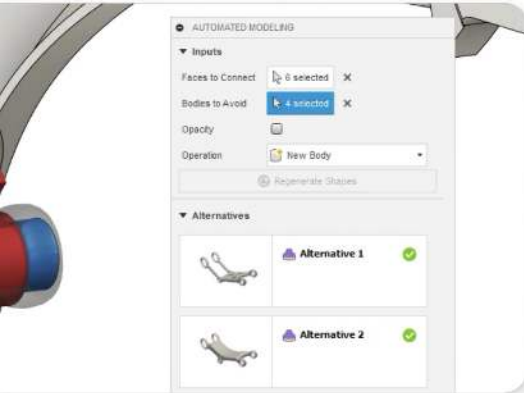

Showing the options:

The system then has enough information to kick in, generating design alternatives directly within the assembly context. The user will preview options for their design to choose from.



Making a selection:

Once the user selects an alternative, it is created as part of the feature history, just as if it had manually been modeled by the user.

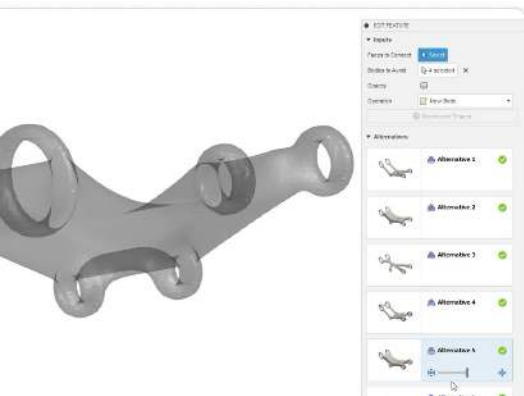

Having more control:

A volume slider is incorporated to give the user more interactive control of the design to accomplish complicated changes with little effort.



Generative Design

What if we told you complex design and engineering challenges could be solved with one designer, in hours vs days or weeks? Well, that is what Generative Design can do.

Generative Design is like Automated Modeling's older sibling. Automated Modeling is looking over your shoulder giving you suggestions, Generative Design is a true partner that gives you the power to simultaneously generate multiple options based on real-world manufacturing constraints and product performance requirements, such as how much load or mass a component should support.

What makes this so unique is that it can analyze all possible variations to a solution and present the list of choices to the user to do the trade off. It is a true exploration of all possibilities to evaluate the potential options and solutions, and pick the right one that meets all the requirements.



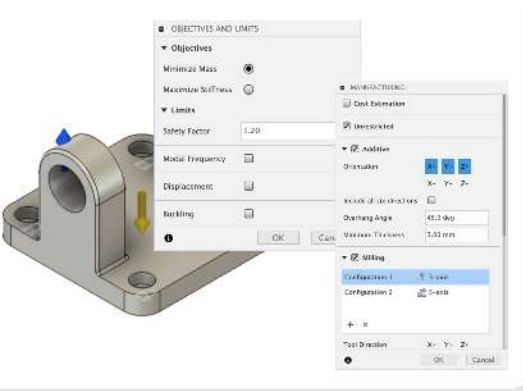

Define the problem:

The user defines the problem they are trying to solve by specifying the constraints and objectives, such as the required performance, and manufacturing constraints.

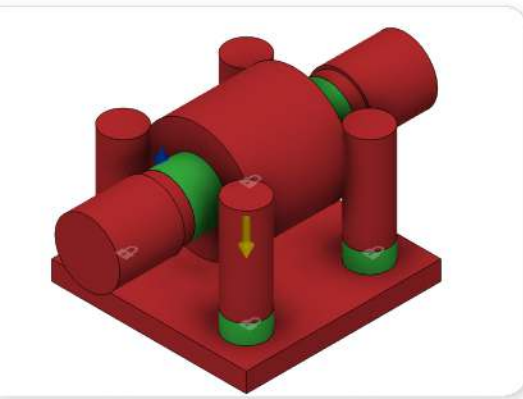

Set up the study:

Next, the user selects the design space. This is where the user specifies the geometry to preserve or avoid, the limits of the study, and defines the load and support conditions.

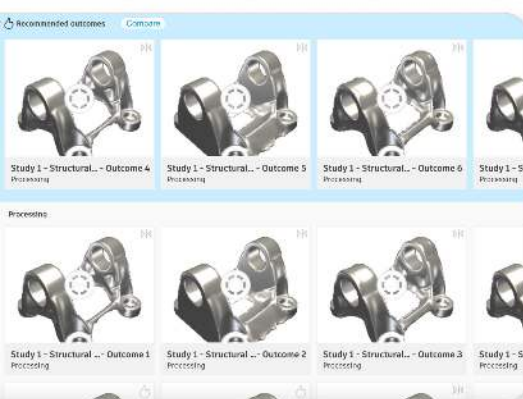

Run the study:

The software will generate multiple design options that meet the specified constraints and objectives.



Evaluate and refine:

Select the best design option, modify the design parameters, and make any necessary adjustments. Then, export the final design as a 3D model and prepare it for manufacturing.



Bring Fusion 360 to the classroom

Now that you have seen what Fusion 360 can do, you are ready to get going with your students in class. Use the link below to log into your educator dashboard and set up your projects, student folders, and assign student permissions.

autode.sk/Fusion360-classroom-project-setup



Introduction to Engineering Design

>  Class Files

▼  Students

>  Bill

>  Fab

>  Gaby

>  Jane

>  _Group 1 Assignment

>  _Group 2 Assignment

Projects:

Create a folder level project. Think of this as your digital classroom space for Fusion 360. This is where students will create their designs and save their assignments.

Folder structure:

Organize your folder structure according to your classroom set up. Start by creating a “Class Files” folder where students are assigned a reader role. This will allow them to view content in this folder, but ensure they are unable to edit or overwrite it.

Student folders:

Create a “Students” folder. Assign students roles to the corresponding subfolder. With a student role, you have control on where a student can open, view, and save files.



*Subfolders will inherit the roles of the parent folder. The parent folder **must have no roles assigned** to it in order to assign an editor role to the subfolder (individual student folder).*

Group folders:

Create group folders for group assignments. This is where you can include multiple students in a folder, as editor roles, to collaborate on their assignment.



You can have more than one folder for group assignments, making classroom collaboration easy - either within one class period or across multiple class periods.



Learning and certifications

As an educator, do you want to level up your skills with Fusion 360? Are your students ready for certifications to test their knowledge of Fusion 360? Check out the learning and certification content we offer to help you and your students in your skills journey.



Learn Fusion 360 in 90 minutes

In Learn Fusion 360 in 90 Minutes, students will learn to navigate the Fusion 360 user interface, create and manage design files, create components and assemblies, define sketches, create solidbodies, modify existing parts, set up and generate product renderings, export files for 3D printing and share designs with others, all with a final test of knowledge.



Try it out in your classroom

Get started with a repository of project ideas to introduce into your classroom! With our Instructables projects, you can find multiple ideas for 3D printing, CNC, laser cutting and more.

Notes





Thank you from Autodesk

From all of us at Autodesk, thank you for teaching and inspiring the next generation of designers and makers. Going beyond the software, our goal is to provide you with all of the resources and partners to help you engage with your students. From learning and certifications to professional development to classroom project ideas, we have what you need.



Let's stay connected

adsktinkercad 

tinkercad 

tinkercad 

AutodeskEducation 

AutodeskEDU 

AutodeskEDU 

Autodesk 